

# General Instructions

## eKDD Series

EC Fan

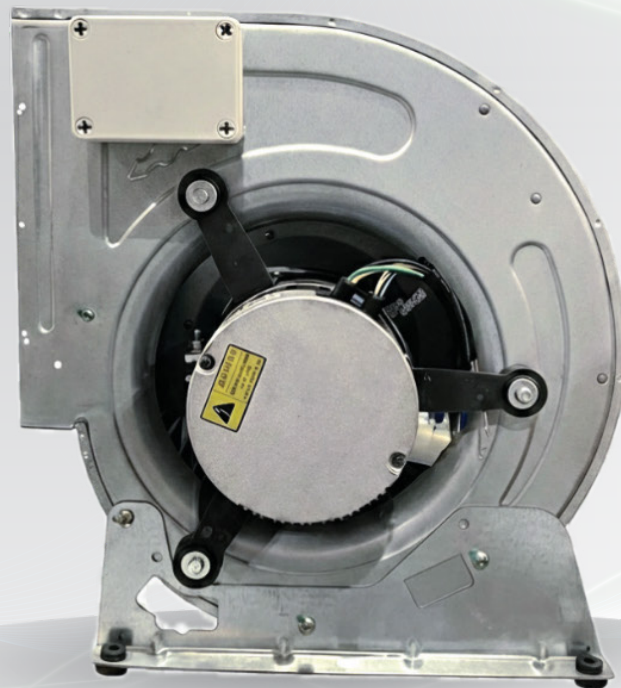

## 1. INTRODUCTION

This manual provides guidance on safety, storage, installation, operation, wiring, and maintenance to ensure safe operation and maximum equipment life. **All handling and maintenance must be carried out by trained and qualified personnel.**

## 2. SAFETY INSTRUCTIONS



- Installation and maintenance must be performed by **qualified personnel only**.
- Always **disconnect the power supply** before installation or maintenance.
- Ensure the fan is properly **grounded (earthing)**.
- Do not operate the fan outside the **specified operating limits**.
- Do not access the fan while the **impeller is in operation**.

## 3. RECEIVING, HANDLING AND STORAGE

Rough handling during shipment and improper storage can cause damage that is not noticeable until the fan is in operation. This can be avoided with proper storage and handling techniques.

- Touch up any scratched coated surfaces during handling to prevent corrosion.
- Store the fan in a clean and dry place, preferably indoors, to ensure the fan shaft, bearings and fan casing are protected against dust and corrosion.
- Do not store the fan in a location where it will be subjected to high vibration.

## 4. START-UP CHECK LIST

Before putting any fan into initial operation, the manufacturer's instructions must be followed.

Complete the following checklist to ensure the fan is ready for operation:

- Lock out the primary and all secondary power sources.
- Ensure the mounting arrangement and duct connections comply with accepted engineering practices.
- Ensure that all fasteners, particularly impeller fasteners, are tight prior to start-up.
- Rotate the impeller manually to confirm free movement and no imbalance.
- Verify that the impeller rotation direction matches the design.
- Connect the fan according to the wiring diagram attached to the unit.
- Ensure the supply voltage matches the rating on the fan nameplate.

Switch on the electrical supply and allow the fan to reach full speed.

Check carefully for:

- 1) Excessive vibration.
- 2) Unusual noise
- 3) Electrical input (current and voltage do not exceed nameplate values)

If any abnormal condition is detected, switch off the fan immediately. Lock out the power supply and secure the impeller if there is a risk of windmilling (i.e. rotation caused by airflow through the system). Identify and rectify the issue before restarting.

During the first 8 hours of operation, periodically check for vibration, noise, motor current, and temperature. After 8 hours, shut down the fan and recheck that all fasteners and mounting bolts are securely tightened.

**\* Note:** *Using the fan outside the specified limit could result in dangerous situations not evaluated and not considered to be the responsibility of the manufacturer.*

## 5. ELECTRICAL & CONTROL WIRING

### i. Wiring Diagram

This section describes the terminal layout and wiring guidelines for eKDD.

The fans support several speed control methods, allowing integration with various building control systems.

### ii. Available Speed Control Methods

1. Standard: Automatic Speed Control (DCV / BMS)
  - Analog control signal: 0–10 VDC
  - Modbus RTU communication via RS485
2. Optional: Manual Speed Control (Potentiometer)
  - Analog control signal: 0–10 VDC

For detailed information on the eKDD Modbus RTU interface, PC software, and configuration procedures, *please contact Kruger.*

### iii. Terminal Description

Terminal	Function	Description
L	Power	Live power supply
N	Power	Neutral power supply
GND	Safety	Protective earth (ground)
VSP	Control	Analog speed control input (0–10 VDC)
C	Control	Analog signal common
RS485A	Communication	Modbus Communication A
RS485B	Communication	Modbus Communication B

### iv. Power Wiring

- Select the cable size according to the motor's input current (A) for each model.
- Shielded cables are not required for power connections.
- Each fan must be protected by an individual circuit breaker when multiple units are installed.

### v. Control Wiring

- Ensure control cables (RS485A, RS485B, VSP, C) are routed to an accessible external location.
- Keep control wiring separated from power supply cables.
- Shielded cables must be used for Modbus RS485 communication.

## 6. ROUTINE MAINTENANCE

Maintenance must be performed by trained personnel only.

- Always isolate and lock out the electrical supply before maintenance.
- Ensure the impeller is secured before any work is carried out.

Under normal clean air conditions, cleaning is typically required once per year. However, the system should be inspected regularly for dust or material build-up.

- Inspect the impeller for dirt accumulation, which may cause imbalance and bearing wear.
- Establish a regular maintenance schedule based on operating conditions.
- Periodically inspect the rotating assembly for signs of corrosion, erosion, or fatigue.

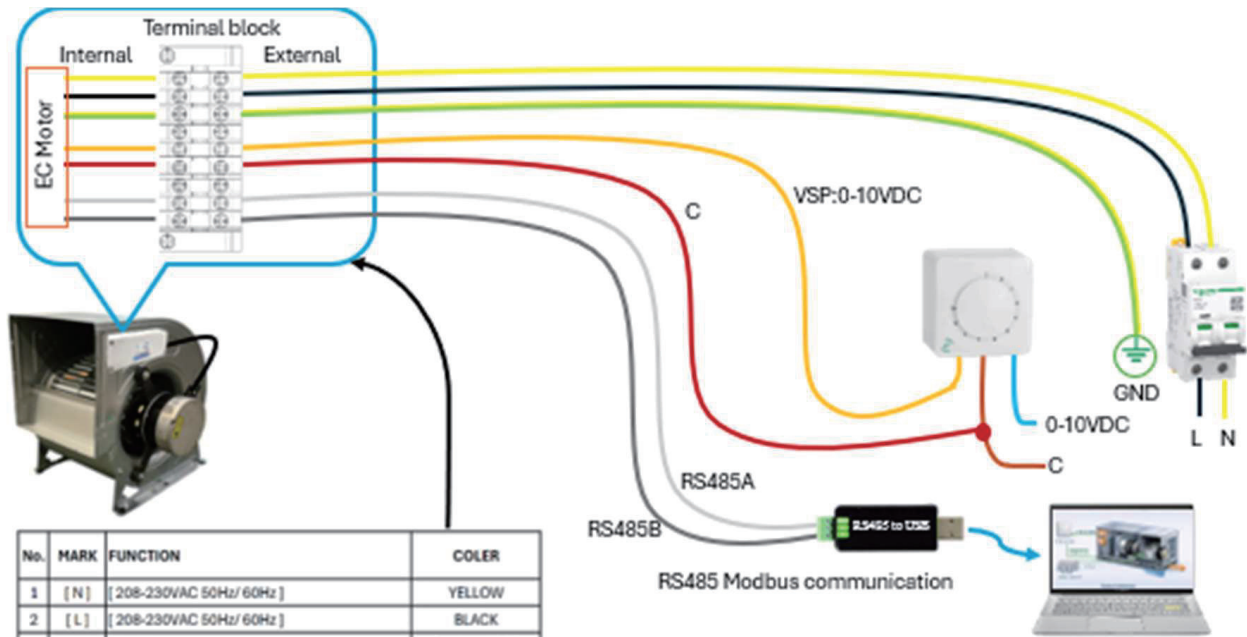

No.	MARK	FUNCTION	COLOR
1	[ N ]	[ 208-230VAC 50Hz/ 60Hz ]	YELLOW
2	[ L ]	[ 208-230VAC 50Hz/ 60Hz ]	BLACK
3	[ GND ]	[ GND ]	YELLOW/GREEN
4	[ / ]	[ / ]	[ / ]
5	[ VSP ]	[ VARIABLE SUPPLY POWER, 0-10VDC ]	ORANGE
6	[ C ]	[ LOW VOLTAGE COMMON ]	BROWN
7	[ / ]	[ / ]	[ / ]
8	[ 485A ]	[ COMMUNICATION VIA MODBUS PROTOCOL ]	WHITE
9	[ 485B ]	[ COMMUNICATION VIA MODBUS PROTOCOL ]	GRAY